

DF-series

floor model hydraulic presses

Standard Features

- Hydro-Guard Plus press control system
- Dual palm button anti-tie-down controls
- LCD operator interface (with H.G. +)
- NFPA-79 compliant electrical controls
- Industry standard components
- NEMA enclosures and TEFC motor
- Emergency stop button & emergency return
- Magnetic motor starter
- Main power disconnect
- Pressure reversal
- Hydraulic decompression control
- In reservoir hydraulic pump for quiet operation
- Inch/Operate selector switch
- Stroke & batch counters (with H.G. +)
- Programmable energy saver timer (with H.G. +)
- Heat exchanger on 5HS, 15M, 30M & 50M power units



DF-Series Floor Model

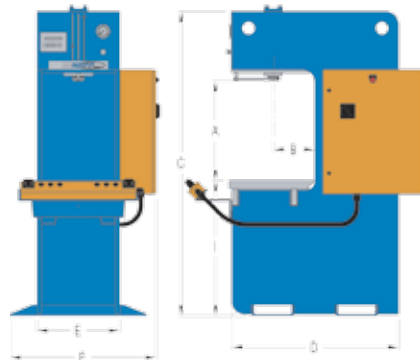

Notes:
Contact Factory for specific CPM information.
High-speed power unit upgrades available for increased cycle rates.

CYCLES/MINUTE (CPM)

TOTAL STROKE	1"	2"	4"	6"	10"
DF15-5HS	42	44	30	23	16
DF15-15M	51	55	47	41	32
DF25-15M	42	47	38	32	24
DF40-15M	32	39	30	25	18
DF50-15M	27	32	25	20	14
DF75-15M	23	27	20	16	11
DF100-30M	28	31	23	18	13
DF150-30M	22	25	18	14	9
DF200-50M	29	31	22	17	12

Model	DF15-5HS	DF15-15M	DF25-15M	DF40-15M	DF50-15M	DF75-15M	DF100-30M	DF150-30M	DF200-50M
Tonnage	.9-18.8	.9-18.8	1.5-29.5	2.0-42.4	3.0-57.7	4.5-75.4	6.0-117.0	9.0-169.0	12-230.9
Piston Diameter	4.0"	4.0"	5.0"	6.0"	7.0"	8.0"	10.0"	12.0"	14.0"
Rod Diameter	2.5"	2.5"	3.5"	4.0"	5.0"	5.5"	7.0"	8.0"	10.0"
Ram Speeds (IPM)	510/60/322	1644/146/1054	839/94/806	642/65/514	411/48/428	340/37/304	375/50/360	287/35/230	301/44/314
Pump Flow (gpm)	11	35	35	35	35	35	62	62	102
Operation PSI	150-3000	150-3000	150-3000	150-3000	150-3000	150-3000	150-3000	150-3000	150-3000
Stroke (adjustable)	.5"-10.0"	0.5"-10.0"	0.5"-10.0"	0.5"-10.0"	0.5"-10.0"	0.5"-10.0"	0.5"-10.0"	0.5"-10.0"	0.5"-16.0"
Motor HP/RPM	5/1800	15/1800	15/1800	15/1800	15/1800	15/1800	30/1800	30/1800	50/1800
Reservoir Capacity	12 gallons	60 gallons	60 gallons	60 gallons	60 gallons	60 gallons	150 gallons	150 gallons	200 gallons
Weight	5500 lbs.	5950 lbs.	5950 lbs.	5950 lbs.	8120 lbs.	8120 lbs.	12700 lbs.	12700 lbs.	20000 lbs.
Daylight (A)	24"	24"	24"	24"	24"	24"	24"	24"	30"
Throat (B)	10"	10"	10"	10"	10"	10"	10"	10"	16"
Height (C)	80"	80"	80"	80"	92"	92"	96"	96"	120"
Depth (D)	58"	58"	58"	58"	66.5"	66.5"	70"	70"	102"
Frame Width (E)	21"	21"	21"	21"	27"	27"	30"	30"	36"
Maximum Width (F)	35"	35"	35"	35"	42"	42"	44"	44"	54"
Bolster (WxDxT)	24x21x3	24x21x3	24x21x3	24x21x3	30x21.5x4	30x21.5x4	33x21.5x4	33x21.5x4	48x31x6
Bolster to Floor (G)	32.625"	32.625"	32.625"	32.625"	32.625"	32.625"	32.625"	32.625"	36"

Making **the presses**
that make **the products**
that make the **World work**



6516 Page Ave.
St. Louis, MO 63133
Phone: (800) 325-8612
Fax: (314) 725-2230
Website: www.neffpress.com

Options

- Part Quality Assurance (PQA)
- High speed power unit
- Automatic press cycles
- Feed integration packages
- Ram position control systems
- Force/distance monitoring

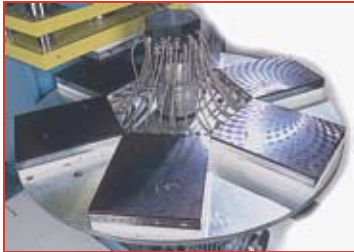

◦ Indexing tables

- Clean Room compliant presses
- CNC controls
- Press benches
- Foot switches
- PLC controls
- Dwell timers



◦ Hydro Guard Plus LCD Display

- Explosion proof presses
- Digital pressure readout peak hold
- Heat exchangers
- Speed controls
- Frame modification
- Press guarding systems



◦ Guided tool mounting plates

Removable Bolsters

for DF-Series floor model hydraulic presses

Note: All dimensions shown are in inches. □ = Neff's Mounting holes

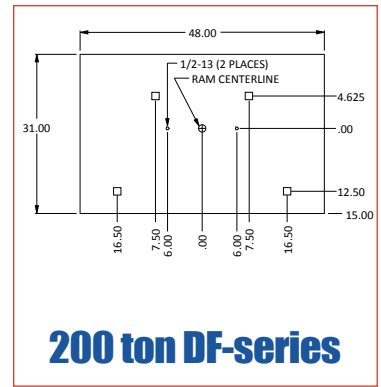
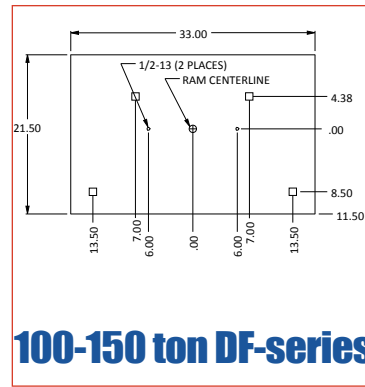
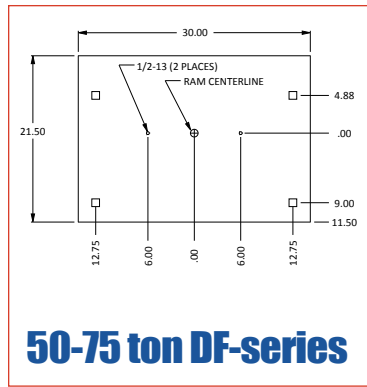
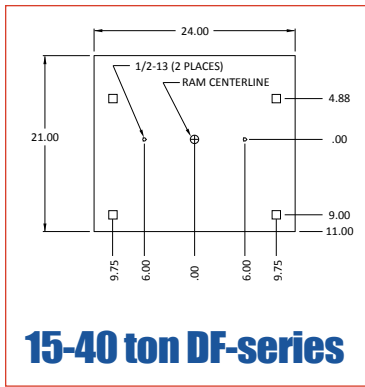

Quick Die Change System

Note: All dimensions shown are in inches.

CYLINDER CAPACITY	DIE CONNECTOR STUD					DIE CONNECTOR RING					
	A	B	C	D	E	F	G	H	I	J	K
15 Ton	2.85	2.38	2.00	4.50	1 7/8-12	5.75	2.970	2.370	17/32	4.625	0.75
25 Ton	2.85	3.38	2.00	5.13	2 1/2-12	5.75	2.970	2.370	17/32	4.625	0.75
40 Ton	2.85	3.63	2.00	5.25	3-12	5.75	2.970	2.370	17/32	4.625	0.75
50 Ton	4.50	4.87	2.50	7.25	3 1/2-12	9.00	3.870	4.620	13/16	7.000	1.25
75 Ton	4.50	5.50	2.50	7.25	4-12	9.00	3.870	4.620	13/16	7.000	1.25
						F1	G1	H1	I1	J1	K1
100 Ton	6.50	6.88	4.50	9.50	5-12	12.50	5.125	6.750	1 1/16	10.000	2.75
150 Ton	6.50	7.88	4.50	9.50	5 3/4-12	12.50	5.125	6.750	1 1/16	10.000	2.75
200 Ton	N/A	N/A	N/A	N/A	N/A	N/A	N/A	N/A	N/A	N/A	N/A

Stud

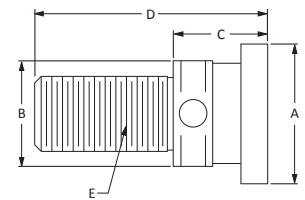

Ring

